

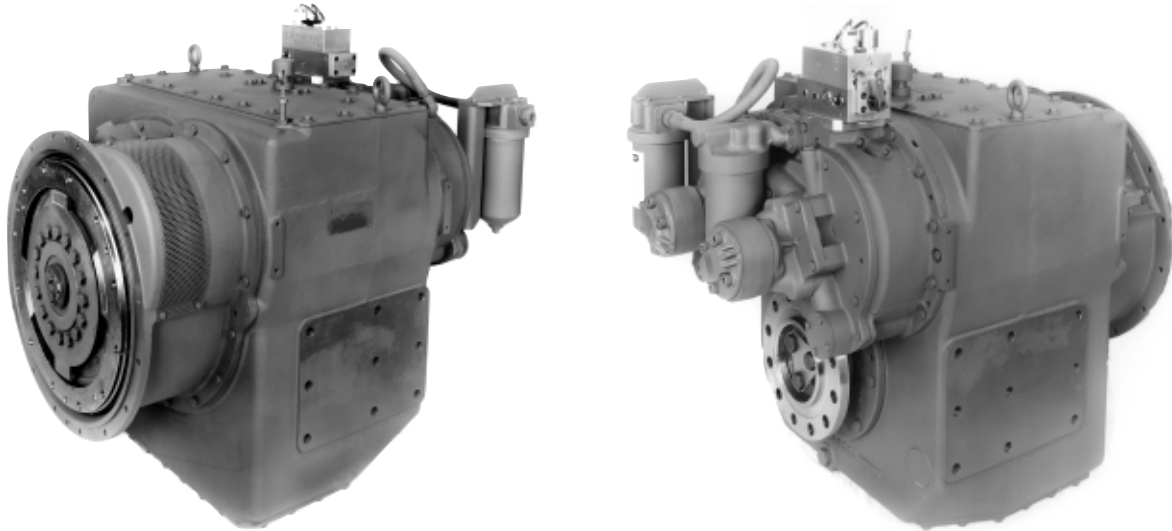

From the Family of Twin Disc Critical Performance Products

## Twin Disc Reverse Reduction Marine Transmission 774 to 1245 kW 1038 to 1670 hp



MG-540 shown with optional torsional coupling and electric selector valve. (Standard companion flange not shown.)

Since its introduction in 1972, the MG-540 transmission has exceeded owners' expectations. A few revisions have been made to the design and engineering of the MG-540 allowing the

model to build a favorable reputation in the marine transmission industry. Production tooling, assembly and testing practices make for a superior quality transmission in this size category. Some

recent changes to the transmission include the addition of torsionally soft couplings and the installation of an optional electric selector valve.

### SAE "0" HOUSING

MODEL ASSY. DWG.	REDUCTION RATIOS	*INPUT RATINGS – KILOWATTS (HORSEPOWER)					MAX. RATED INPUT SPEED, AND MIN. ENGINE LOW IDLE SPEED RPM
		INTERMEDIATE DUTY 1900 RPM	MEDIUM DUTY		CONTINUOUS DUTY		
		1200 RPM	1800 RPM	1200 RPM	1800 RPM		
X9882A	1.93	1245 (1670)	787 (1056)	1180 (1583)	787 (1056)	1180 (1583)	575 RPM MIN
	2.58	1245 (1670)	787 (1056)	1180 (1583)	787 (1056)	1180 (1583)	
	2.90	1245 (1670)	787 (1056)	1180 (1583)	787 (1056)	1180 (1583)	
	3.26	1245 (1670)	776 (1040)	1163 (1560)	776 (1040)	1163 (1560)	
	3.91	1063 (1425)	648 (869)	972 (1303)	648 (869)	972 (1303)	MAX: 1900 RPM-1.93, 2.58, 2.90, 4.60
	4.60	1245 (1670)	787 (1056)	1180 (1583)	787 (1056)	1180 (1583)	
	5.17	1230 (1650)	774 (1038)	1161 (1557)	774 (1038)	1161 (1557)	
	6.18	1029 (1380)	–	966 (1295)	–	966 (1295)	
	7.00	–	–	857 (1149)	–	857 (1150)	
	7.47	–	–	804 (1078)	–	804 (1078)	

Please refer to back cover for service classification definitions.

\*Ratings shown based on MG-540 use with standard rotation diesel engines and the use of a suitable input torsional coupling. Consult Twin Disc for capacity or input rating for use with non-standard rotation diesel engines or use of non-torsionally soft input coupling. Please also refer to "Important Notice" statement in this bulletin as to torsional vibrations.

### SAE "00" HOUSING

MODEL ASSY. DWG.	REDUCTION RATIOS	*INPUT RATINGS – KILOWATTS (HORSEPOWER)					MAX. RATED INPUT SPEED, AND MIN. ENGINE LOW IDLE SPEED RPM
		INTERMEDIATE DUTY 1900 RPM	MEDIUM DUTY		CONTINUOUS DUTY		
		1200 RPM	1800 RPM	1200 RPM	1600 RPM		
X9942A	1.71	1245 (1670)	787 (1056)	1180 (1583)	787 (1056)	1050 (1408)	575 RPM MIN
	1.93	1245 (1670)	787 (1056)	1180 (1583)	787 (1056)	1050 (1408)	
	2.59	1245 (1670)	787 (1056)	1180 (1583)	787 (1056)	1050 (1408)	
	2.90	1245 (1670)	787 (1056)	1180 (1583)	787 (1056)	1050 (1408)	
	3.26	1245 (1670)	776 (1040)	1163 (1560)	776 (1040)	1034 (1386)	MAX: 1650 RPM-1.71, 2.59, 4.10
	4.10	1245 (1670)	787 (1056)	1180 (1583)	787 (1056)	1050 (1408)	
	4.60	1245 (1670)	787 (1056)	1180 (1583)	787 (1056)	1050 (1408)	
	5.17	1230 (1650)	774 (1038)	1161 (1557)	774 (1038)	1033 (1385)	
	6.18	1029 (1380)	–	966 (1295)	–	859 (1152)	

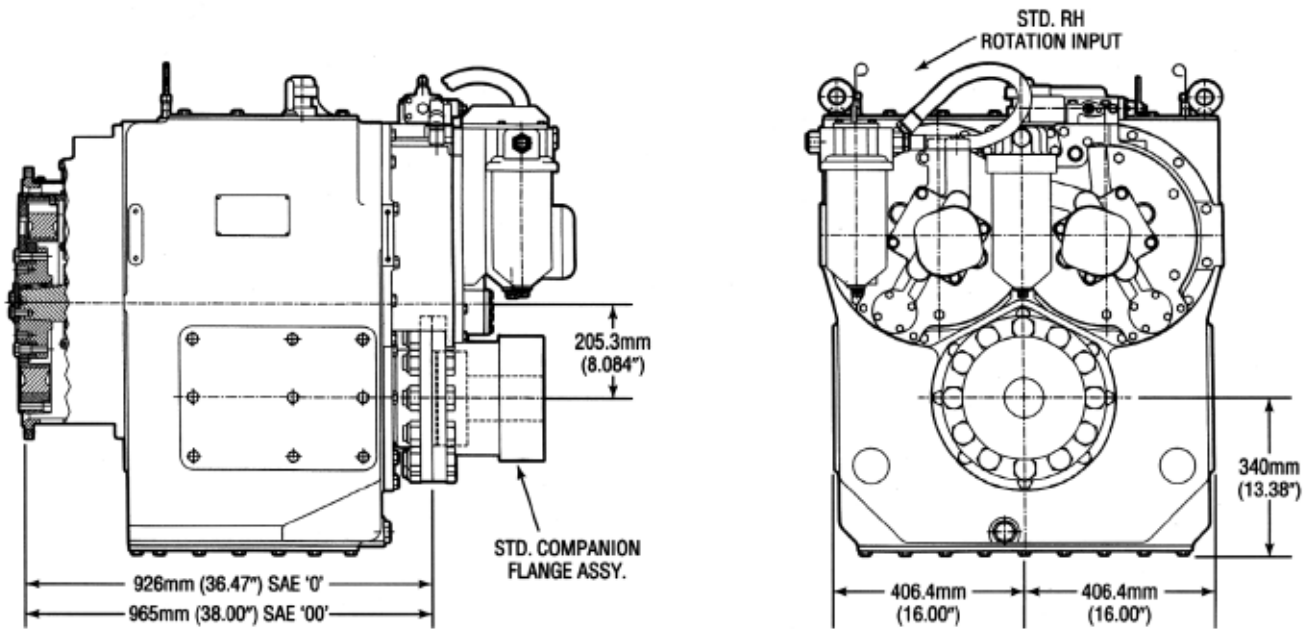

MG-540 shown with mechanical selector valve.

### Specifications—MG-540:

- Dry weight
  - MG-540 SAE '0'-2019 Kg (4450 lbs)
  - MG-540 SAE '00'-2105 Kg (4640 lbs)
- Input couplings
  - Non-torsional type-18"/21" RBD
  - Torsional type-18"/21"
- Companion flange/bolt set
- Mechanical type selector valve
- Oil strainer/filter assemblies
- Oil pressure/oil temperature gauges
- Low oil pressure cooling circuit

### Options:

- Use with L.H., non-standard rotation engines.
- Free-standing arrangement-consult Twin Disc for details.
- Heat exchangers for raw water (K-109) and Freshwater (165° F max., K-110)
- Trolling valves
- 12V or 24V electric selector valve
- Mounting brackets
- ABS or other major marine classification societies approval/certificates - consult Twin Disc for details.

Specifications subject to change without prior notice in the interest of continual product improvement.

### Service Classification Definitions

#### Intermediate Duty

Hour usage of up to 2000 hours/year (for models MG-5114 and smaller) and up to 3000 hours/year (for models MG-5141 and larger) with 50% of the operating time at full engine rating.

Typical applications include planing hull vessels such as ferries, fishing boats, some crew boats, and also some displacement hull yachts as well as some bow and stern thruster applications.

#### Medium Duty

Hours usage of up to 4000 hours/year with up to 80% of operating time at full engine power. This duty classification is for usage where some variations in engine speed/power occur as part of normal vessel operation.

Typical vessels include mid-water trawlers, crew/supply boats, ferries, and some inland water tow boats.

#### Continuous Duty

For use in continuous operation with little or no variation in engine speed/power settings.

Typical vessels include fishing trawlers, tow/tug boats and ocean going vessels.

**Important Notice: Torsional Vibration** Disregarding propulsion system torsional compatibility could cause damage to components in the drive train resulting in loss of mobility. At minimum, system incompatibility could result in gear clatter at low speeds.

The responsibility for ensuring that the torsional compatibility of the propulsion system is satisfactory rests with the assembler of the drive and driven equipment.

Torsional vibration analysis can be made by the engine builder, marine survey societies, independent consultants and others. Twin Disc is prepared to assist in finding solutions to potential torsional problems that relate to the marine transmission.

Twin Disc, Incorporated reminds users of these products that their safe operation depends on use in compliance with engineering information provided in this bulletin. User are also reminded that safe operation depends on proper installation, operation and routine maintenance and inspection under prevailing conditions. It is the responsibility of user (and not Twin Disc, Incorporated) to provide and install guards or safety devices which may be required by recognized safety standards or by the Occupational Safety and Health Act of 1970 and its subsequent provision.



Twin Disc, Incorporated  
 Racine, Wisconsin 53403, U.S.A.  
 262-638-4000/262-638-4482 (fax)  
<http://www.twindisc.com>  
 Singapore, Australia, Italy  
 Twin Disc International S.A.  
 1400 Nivelles, Belgium