

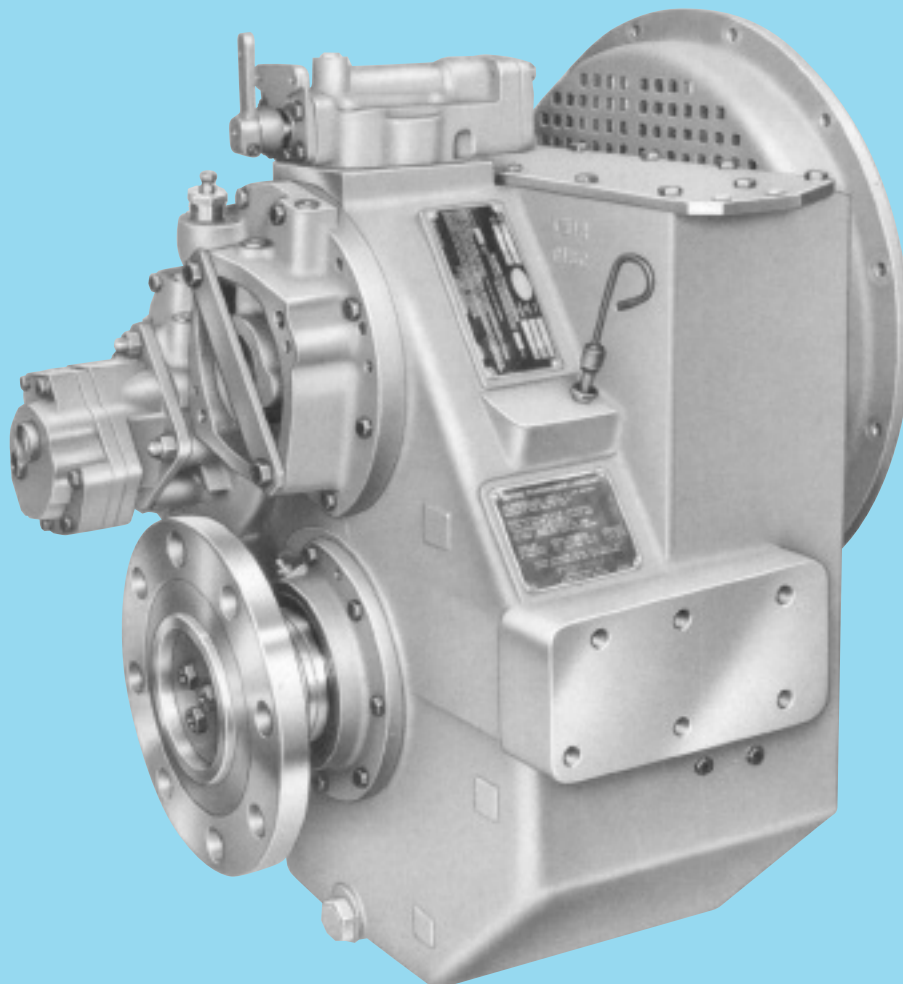

BULLETIN 319-A-91D

MODEL MG-5091 DEEP CASE MARINE TRANSMISSION

124 to 336 kW (167 to 450 hp)



TWIN DISC, INCORPORATED • RACINE, WISCONSIN 53403, U.S.A.

©1992, Twin Disc, Incorporated

MODEL MG-5091 DEEP CASE

- 250 hp @ 1800 rpm continuous duty
- 655 lbs for low cost to hp
- Popular PTO options
- Trolling valve option
- Identical forward and reverse ratios: 3.82:1, 4.50:1 and 5.10:1
- Identical capacity forward or reverse — provides either left or right-hand propeller rotation with identical right-hand engines
- Helical gears for quieter operation
- Oil controlled and cooled clutches
- Clutches can be serviced with transmission attached to engine
- No external plumbing (except to heat exchanger)
- Built with jig-bore accuracy
- SAE No. 1 or No. 2 housing
- Rubber block drive standard
- Optional Torsional Input Couplings
- Advanced design to provide strong yet lightweight high grade iron housings

The MG-5091 Deep Case Marine Transmission design and manufacturing is based on the latest in gear/clutch technology and gearing/bearing/clutch arrangements. The result: a high capacity compact reverse-reduction marine transmission ideally suited for the rugged service encountered by today's harder working diesel engines. For use in vessels such as fishboats, towboats, tugs, ferries, crewboats, etc.

All ratios are available in one housing configuration. Identical capacity and ratios in forward or reverse eliminate the need for opposite rotation engines. Transmissions can be specified for use with LH Rotation Engines. The MG-5091 DC offers unusually good access for service of major components without having to be removed from the engine.

TROLLING VALVE

An optional trolling valve is available for the MG-5091DC. The trolling valve provides the ability to obtain lower propeller speeds than would be possible at engine idle speed with the clutch fully

engaged. If a raw water heat exchanger is used, then a thermostatic oil bypass valve is recommended for use in the transmission oil circuit to provide proper sump oil temperature for consistent trolling valve operation.

HEAT EXCHANGER

Heat exchanger kits for cooling the MG-5091DC are available from Twin Disc. Customers who wish to furnish their own heat exchanger should contact the nearest Twin Disc or marine engine distributor for exchanger specifications.

POWER TAKE-OFFS

Three optional PTO's are available for the MG-5091 DC:

- XB6243 Live SAE C pump-mount PTO rated 112 kW (150 hp) @ 1800 rpm
- XA7554A Hydraulic Clutched SAE C pump-mount PTO rated 78 kW (104 hp) @ 1800 rpm.
- XA7554 Hydraulic Clutched 1 7/8" diameter shaft drive PTO rated 78 kW (104 hp) @ 1800 rpm.

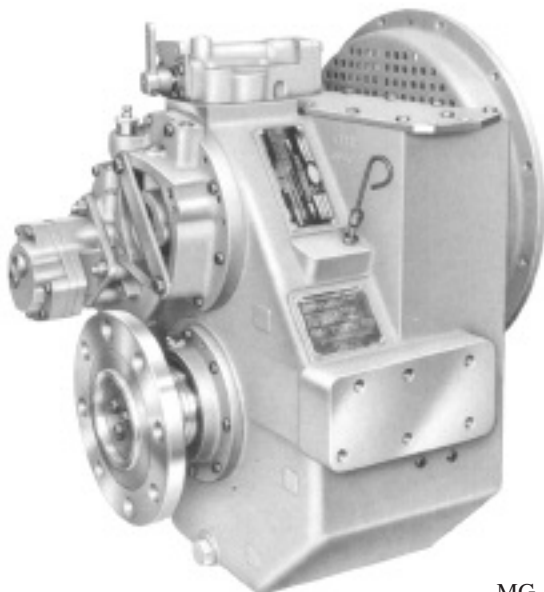

MG-5091DC

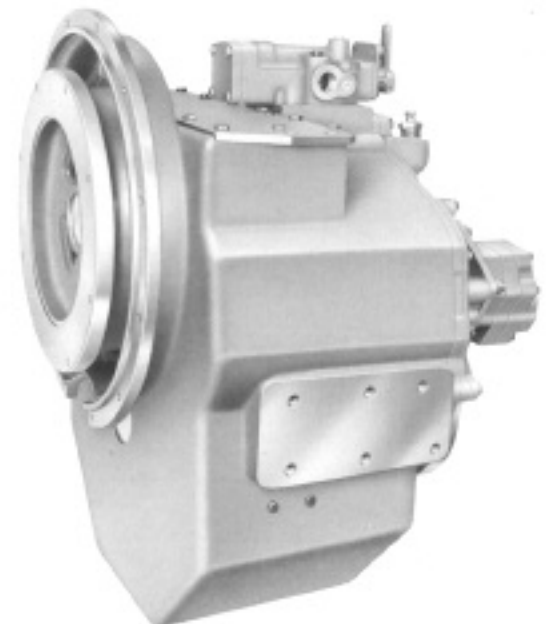

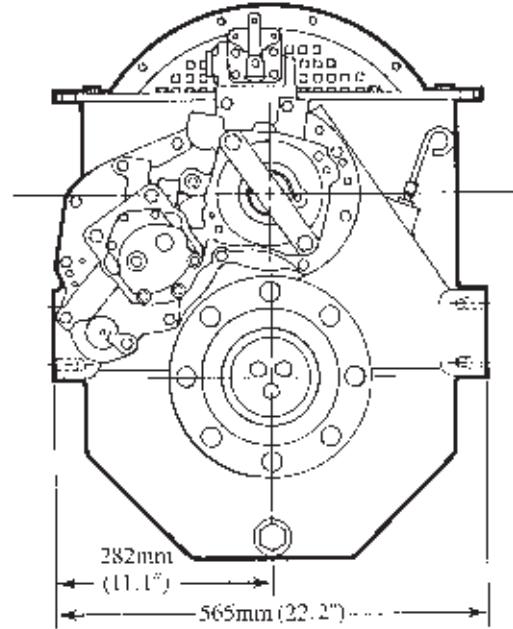
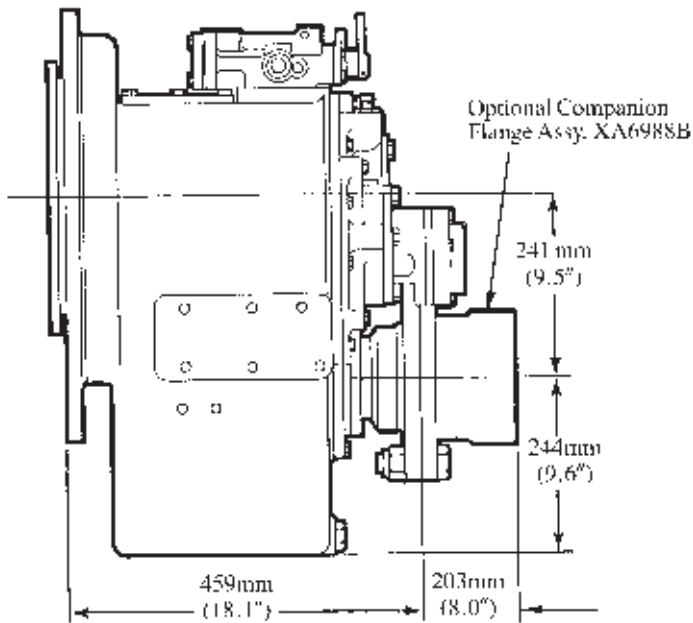

MG-5091 DEEP CASE

DRAWING NUMBER	RATIOS	APPROX. DRY WEIGHT
1002155	3.818:1 4.500:1 5.095:1	297kg (655 lb)

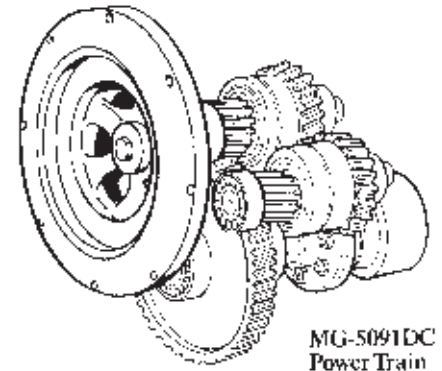

Use Certified Print for Installation

INPUT POWER RATINGS — KILOWATTS (HORSEPOWER)

CONTINUOUS DUTY

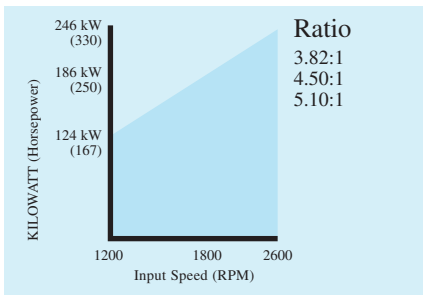

INTERMEDIATE DUTY

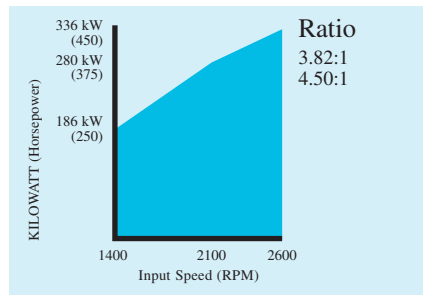

SERVICE CLASSIFICATION DEFINITIONS

CONTINUOUS DUTY

Often called "Work Boat Duty," these marine transmission applications are expected to operate continuously at full engine governed speed. The propulsion engine power setting must be known and must be within the marine transmission's allowable input rating for continuous day long or around the clock service.

Most displacement hull vessels are powered for Continuous Duty service. However, the actual engine (and marine transmission) power loading depends on:

- a. The propeller used
- b. The vessel's work assignment
- c. The captain's choice of throttle setting during continuous service

Twin Disc recommends that all displacement and semi-displacement hull commercial applications be classed as Continuous Duty usage of the marine transmission.

Examples:

Fishing trawlers
Purse seiners
Lobster boats and crab boats
Tugs
Tow boats
Buoy tenders
Offshore supply boats
Ferries
Research vessels
Ocean freighters

INTERMEDIATE DUTY

Pleasure or Commercial usage of planing or semi-displacement hull craft can qualify for Intermediate Duty Service Classification if full throttle operation will average only a few hours per day with major portion of usage at partial throttle and total annual usage will be 2000 hours or less.

Examples:

Long Range Pleasure Cruisers
Sportfish Charter Boats
Party Fishing Boats
Crew Boats
Harbor and Coastal Patrol Boats
Search and Rescue Boats
Fire Boats

IMPORTANT NOTICE

Disregarding propulsion system torsional compatibility could cause damage to components in the drive train resulting in loss of mobility. At minimum, system incompatibility could result in gear clatter at low speeds.

The responsibility for ensuring that the torsional compatibility of the propulsion system is satisfactory rests with the assembler of the drive and driven equipment.

Torsional vibration analysis can be made by the engine builder, marine survey societies, independent consultants and others. Twin Disc is prepared to assist in finding solutions to potential torsional problems that relate to the marine transmission.



Twin Disc, Incorporated
Racine, Wisconsin 53403, U.S.A.
262-638-4000/262-638-4482 (fax)
<http://www.twindisc.com>
Singapore, Australia, Italy
Twin Disc International S.A.
1400 Nivelles, Belgium

IMPORTANT NOTICE: Twin Disc, Incorporated reminds users of these products that their safe operation depends on use in compliance with engineering information provided in this catalog. Users are also reminded that safe operation depends on proper installation, operation and routine maintenance and inspection under prevailing conditions. It is the responsibility of users (and not Twin Disc, Incorporated) to provide and install guards or safety devices which may be required by recognized safety standards or by the Occupational Safety and Health Act of 1970 and its subsequent provisions.

nance and inspection under prevailing conditions. It is the responsibility of users (and not Twin Disc, Incorporated) to provide and install guards or safety devices which may be required by recognized safety standards or by the Occupational Safety and Health Act of 1970 and its subsequent provisions.