

TA90-8501 TA91-8501 Up to 3000hp 2300kW

Twin Disc Automatic Transmission Systems

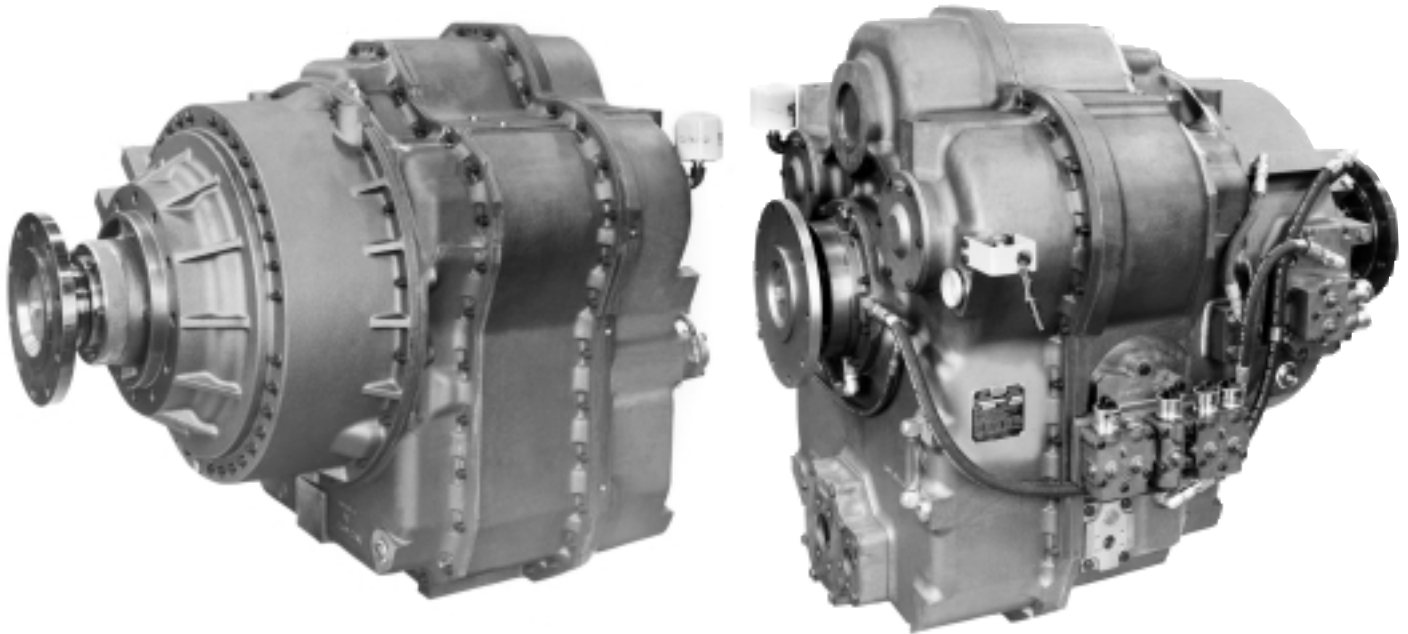

TA91-8501 shown with standard equipment

The 8501 Series transmission system consists of an engine mounted 21 or 23 inch type 8 torque converter, a 9 speed coaxial power-shift transmission and an advanced electronic control system.

Applications

- Oil Field Fracturing Rigs
- Mine Haul Trucks
- Anchor Hoists
- Large Cranes
- Special Purpose Equipment

Features and Benefits

- Increased performance: efficient gear train combined with electronic controls tailored to the needs of the specific application to optimize machine performance.
- Ease of operation: available automatic shifting or manual power shift combined with shift inhibits and interlocks simplify the operator's job and allows for concentration on the job rather than the powertrain.
- Reduced downtime: durable heavy-duty components combined with electronic controls which prevent overspeed, shift shocks and reduce the effects of operator's error, result in increased machine availability and less wear and tear on other machine components.
- Safety: the control system looks after the transmission so the operator can focus on the operation of the machine. Speeds and interlocks can be programmed to meet the needs of the specific machine.

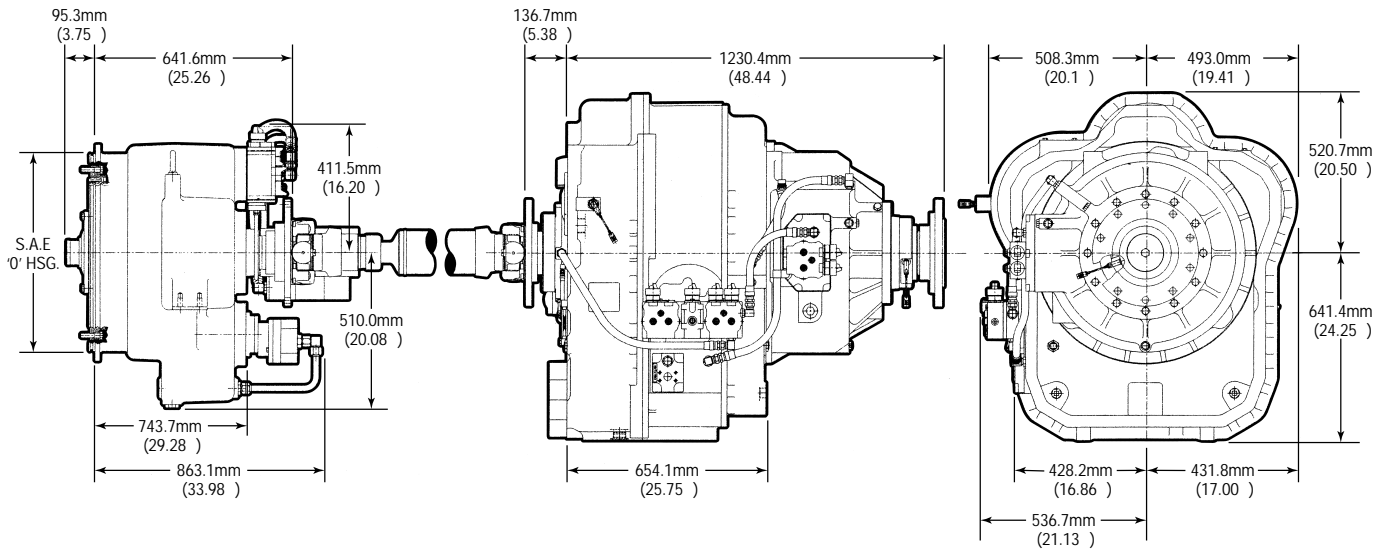

Specifications

Maximum gross input power	3000 hp (2300 kW) at 2100 RPM
Maximum gross input torque	9500 lb-ft (12 880 N-m)
Maximum input speed	2100 RPM

Torque Converter

Models

8FLW-2106	Up to 1300 hp (969 kW)
8FLW-2302	1300 to 3000 hp (969 kW to 2238 kW)

Mounting

SAE 0 wet flywheel housing

PTOs

1 Engine driven SAE "C" pump drive
1.0:1 ratio

Weight, dry
1600 lbs. (726 kg)

Transmission

Models

TA90-8501 9 forward speeds, no reverse
TA91-8501 9 forward speeds and 1 reverse

Mounting

Remote mounted using "trunion" style
mounts.
Sump capacity 35 USG (132 liters)

Weight, dry
5020 lbs. (2288 kg)

Ratios

1st	2nd	3rd	4th	5th	6th	7th	8th	9th	Rev	Overall
4.47	3.57	2.85	2.41	1.92	1.54	1.25	1.0	.80	4.12	5.60

Cooling pump capacity 100 GPM @ 1900 RPM
Maximum oil temperature at converter outlet: 250° F
Cooling required 20 to 30% of GHP depending on application

Consult Twin Disc regarding availability and specifications for optional hydraulic retarder.

Important Notice: Torsional Vibration Disregarding propulsion system torsional compatibility could cause damage to components in the drive train resulting in loss of mobility. At minimum, system incompatibility could result in gear clatter at low speeds.

The responsibility for ensuring that the torsional compatibility of the propulsion system is satisfactory rests with the assembler of the drive and driven equipment.

Torsional vibration analysis can be made by the engine builder, marine survey societies, independent consultants and others. Twin Disc is prepared to assist in finding solutions to potential torsional problems that relate to the marine transmission.

Twin Disc, Incorporated reminds users of these products that their safe operation depends on use in compliance with engineering information provided in this bulletin. Users are also reminded that safe operation depends on proper installation, operation and routine maintenance and inspection under prevailing conditions. It is the responsibility of user (and not Twin Disc, Incorporated) to provide and install guards or safety devices which may be required by recognized safety standards or by the Occupational Safety and Health Act of 1970 and its subsequent provisions.



Twin Disc, Incorporated
Racine, Wisconsin 53403, U.S.A.
262-638-4000/262-638-4482 (fax)
<http://www.twindisc.com>
Singapore, Australia, Italy
Twin Disc International S.A.
1400 Nivelles, Belgium

Bulletin TA91-8501 03/00
©2000, Twin Disc, Incorporated
Printed in United States of America